

## Spare parts list

### Forward and reversible plate

	Valid from serial number
LG 300 Honda Manual start 500 mm	13003001
LG 300 Honda Manual start 500 mm Bio	13003001
LG 300 Honda Manual start 600 mm	13003001
LG 300 Honda Manual start 600 mm Bio	13003001
LG 300 Hatz Electric start 500 mm	13003001
LG 300 Hatz Electric start 500 mm Bio	13003001
LG 300 Hatz Electric start 600 mm	13003001
LG 300 Hatz Electric start 600 mm Bio	13003001
LG 300 Hatz Manual start 500 mm	13003001
LG 300 Hatz Manual start 500 mm Bio	13003001
LG 300 Hatz Manual start 600 mm	13003001
LG 300 Hatz Manual start 600 mm Bio	13003001

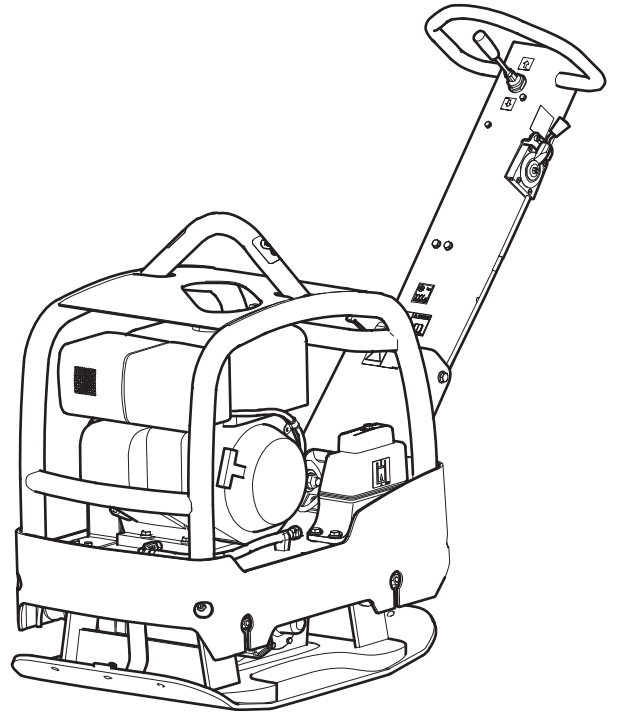



# Contents

<b>General information</b> .....	5
<b>Spare parts list</b> .....	6
<b>Frame, Honda</b> .....	6
<b>Frame and hoods, Hatz</b> .....	8
<b>Engine plate</b> .....	10
<b>Ground plate and eccentric element installation</b> .....	12
<b>Block paving plate 500 mm (19.7 in.)</b> .....	14
<b>Block paving plate 600 mm (23.6 in.)</b> .....	16
<b>Transport device</b> .....	18
<b>Eccentric element</b> .....	20
<b>Engine installation, Honda</b> .....	22
<b>Engine installation, Hatz</b> .....	24
<b>Centrifugal clutch, Honda</b> .....	26
<b>Centrifugal clutch, Hatz</b> .....	28
<b>Belt tightner</b> .....	30
<b>Hydraulic system</b> .....	32
<b>Battery installation</b> .....	34
<b>Handle</b> .....	36
<b>Throttle control, Honda</b> .....	38
<b>Throttle control, Hatz</b> .....	40
<b>Labels, Honda</b> .....	42
<b>Labels, Hatz</b> .....	44
<b>Kits</b> .....	46
<b>One year service kit, Honda</b> .....	46
<b>One year service kit, Hatz</b> .....	46
<b>Shock absorber repair kit</b> .....	47
<b>Eccentric element repair kit</b> .....	47
<b>Forward and reverse piston repair kit</b> .....	48
<b>Block paving plate kit 500 mm (19.7 in.)</b> .....	48
<b>Block paving plate kit 600 mm (23.6 in.)</b> .....	49
<b>Transport device kit</b> .....	50



## General information

This spare parts list applies to the following:

Part number	Description
3382 0000 39	Forward and reversing plate LG 300 Honda Manual start 500 mm (19.68 in.)
3382 0000 45	Forward and reversing plate LG 300 Honda Manual start 500 mm (19.68 in.) Bio
3382 0000 41	Forward and reversing plate LG 300 Honda Manual start 600 mm (23.62 in.)
3382 0000 47	Forward and reversing plate LG 300 Honda Manual start 600 mm (23.62 in.) Bio
3382 0000 38	Forward and reversing plate LG 300 Hatz Electric start 500 mm (19.68 in.)
3382 0000 44	Forward and reversing plate LG 300 Hatz Electric start 500 mm (19.68 in.) Bio
3382 0000 36	Forward and reversing plate LG 300 Hatz Electric start 600 mm (23.62 in.)
3382 0000 42	Forward and reversing plate LG 300 Hatz Electric start 600 mm (23.62 in.) Bio
3382 0000 37	Forward and reversing plate LG 300 Hatz Manual start 500 mm (19.68 in.)
3382 0000 46	Forward and reversing plate LG 300 Hatz Manual start 500 mm (19.68 in.) Bio
3382 0000 40	Forward and reversing plate LG 300 Hatz Manual start 600 mm (23.62 in.)
3382 0000 48	Forward and reversing plate LG 300 Hatz Manual start 600 mm (23.62 in.) Bio

Use only authorized parts. Any damage or malfunction caused by the use of unauthorized parts is not covered by Warranty or Product Liability. Any unauthorized use or copying of the contents or any part thereof is prohibited. This applies in particular to trademarks, model denominations, part numbers, and drawings.

### Instructions for use

This spare parts list contains no safety regulations and is merely intended to assist in the ordering of spare parts.

For information about operating, servicing, or repairing, the relevant Safety and operating instructions must be consulted at all costs.

Please observe the safety instructions listed in the relevant Safety and operating instructions!

# Spare parts list

## Frame, Honda

---

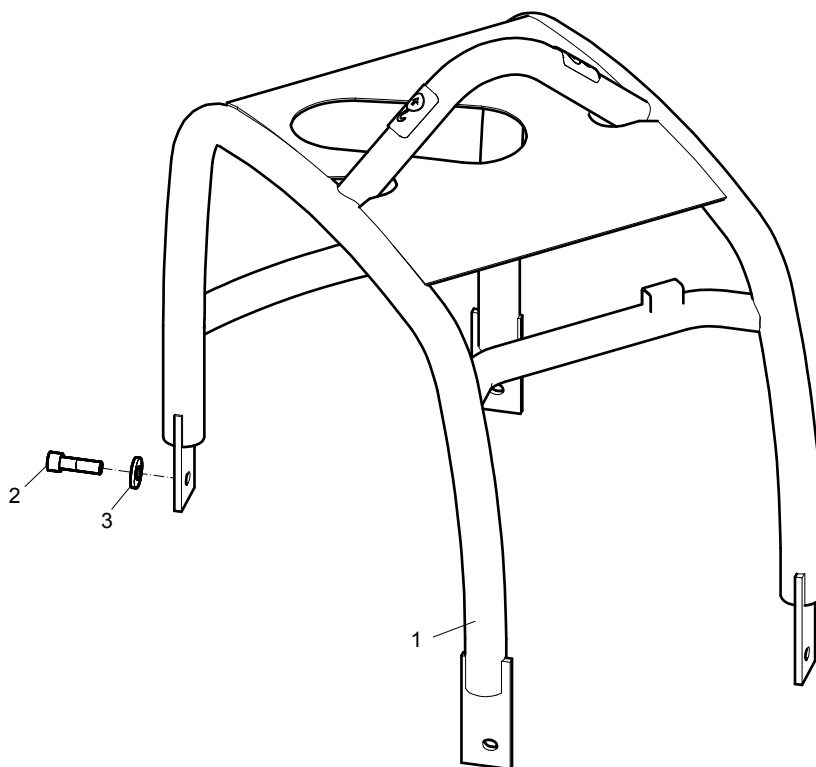

No.	Description	Remark	Quantity	Part number
1	Protective frame		1	3382 0101 59
2	Screw		4	4700 5080 63
3	Washer	13 x 30 x 4 mm 0.51 x 1.18 x 0.16 in. 300 HV	4	4700 9042 13

# Frame and hoods, Hatz

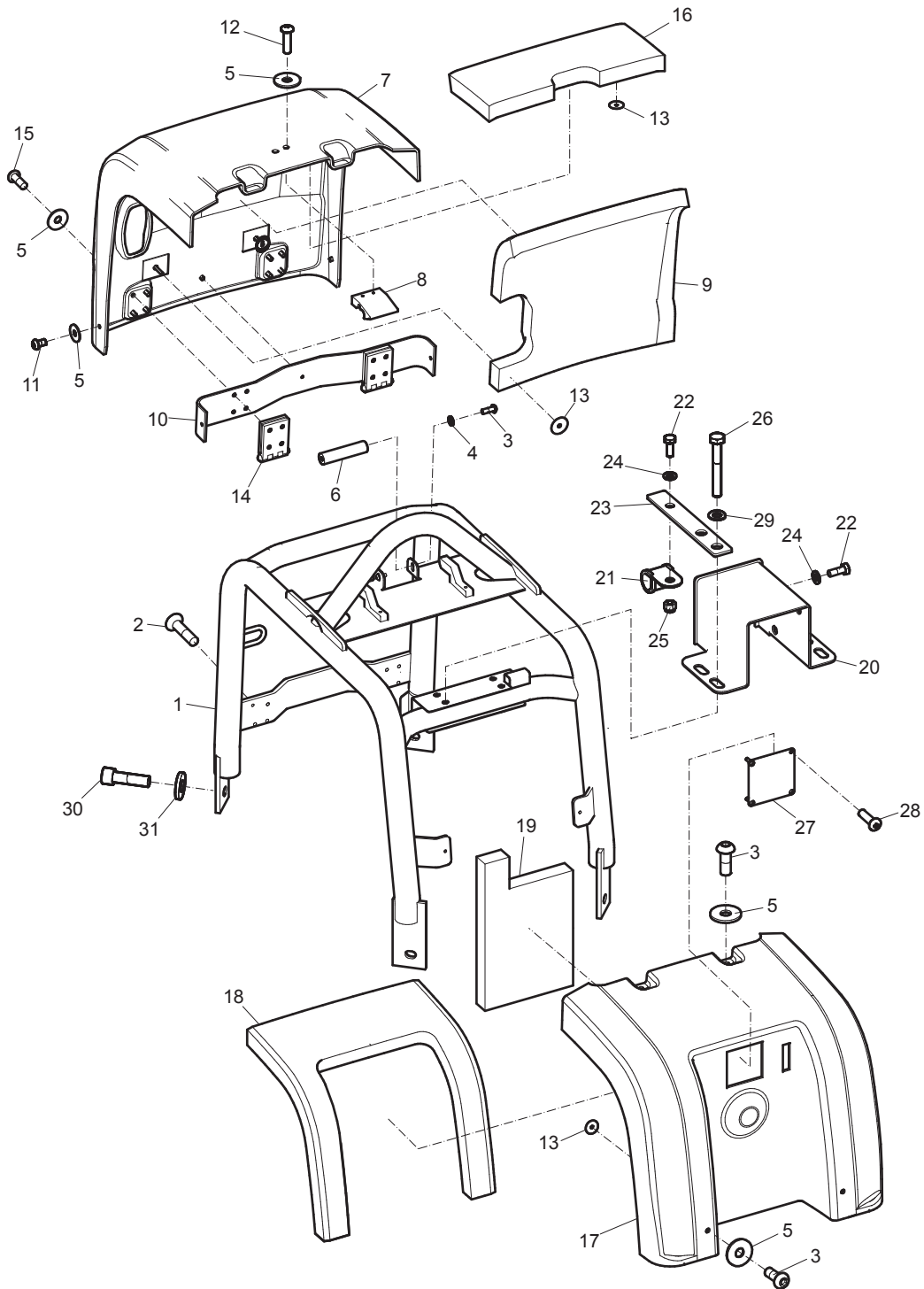



No.	Description	Remark	Quantity	Part number
1	Protective frame		1	3382 0101 68
2	Screw	M6 x 16 mm A2-70	1	-
3	Screw	M6 x 16 mm A2-70	4	-
4	Washer	6.4 x 12 x 1.5 mm 0.25 x 0.47 x 0.06 in. 300 HV	1	-
5	Washer	6 x 18 x 2 mm 0.24 x 0.71 x 0.08 in. 300 HV	5	-
6	Bar		1	4700 3794 33
7	Front hood		1	3382 0101 72
8	Clip		1	4700 3789 27
9	Insulation		1	4700 3790 45
10	Holder		1	4700 3794 02
11	Screw	M6 x 10 mm A2-70	3	-
12	Screw	K50 x 18 mm	2	-
13	Insulating washer	25 mm Type S3 0.98 in.	14	4700 7912 34
14	Hinge		2	4700 3818 82
15	Screw	M6 x 16 mm A2-70	8	-
16	Insulation		1	4700 3904 85
17	Hood		1	3382 0101 73
18	Insulation		1	4700 3790 46
19	Insulation		1	4700 3790 47
20	Holder		1	4700 3787 56
21	Clamp		2	4700 9210 31
22	Screw	M6 x 16 mm 8.8 A2K	6	-
23	Bracket		1	4700 3904 87
24	Washer	6.4 x 12 x 1.5 mm 0.25 x 0.47 x 0.06 in. 300 HV	4	-
25	Lock nut	M6 ISO7040	2	-
26	Screw	M8 x 60 mm 8.8 A2K	4	-
27	Cover		1	3382 0101 56
28	Screw	K50 x 18 mm	4	-
29	Washer	8.4 x 16 x 1.5 mm 0.33 x 0.63 x 0.06 in. 300 HV	4	-
30	Screw	M12 x 40 mm 8.8 A3K	4	-
31	Washer	13 x 30 x 4 mm 0.51 x 1.18 x 0.16 in. 300 HV	4	-

# Engine plate

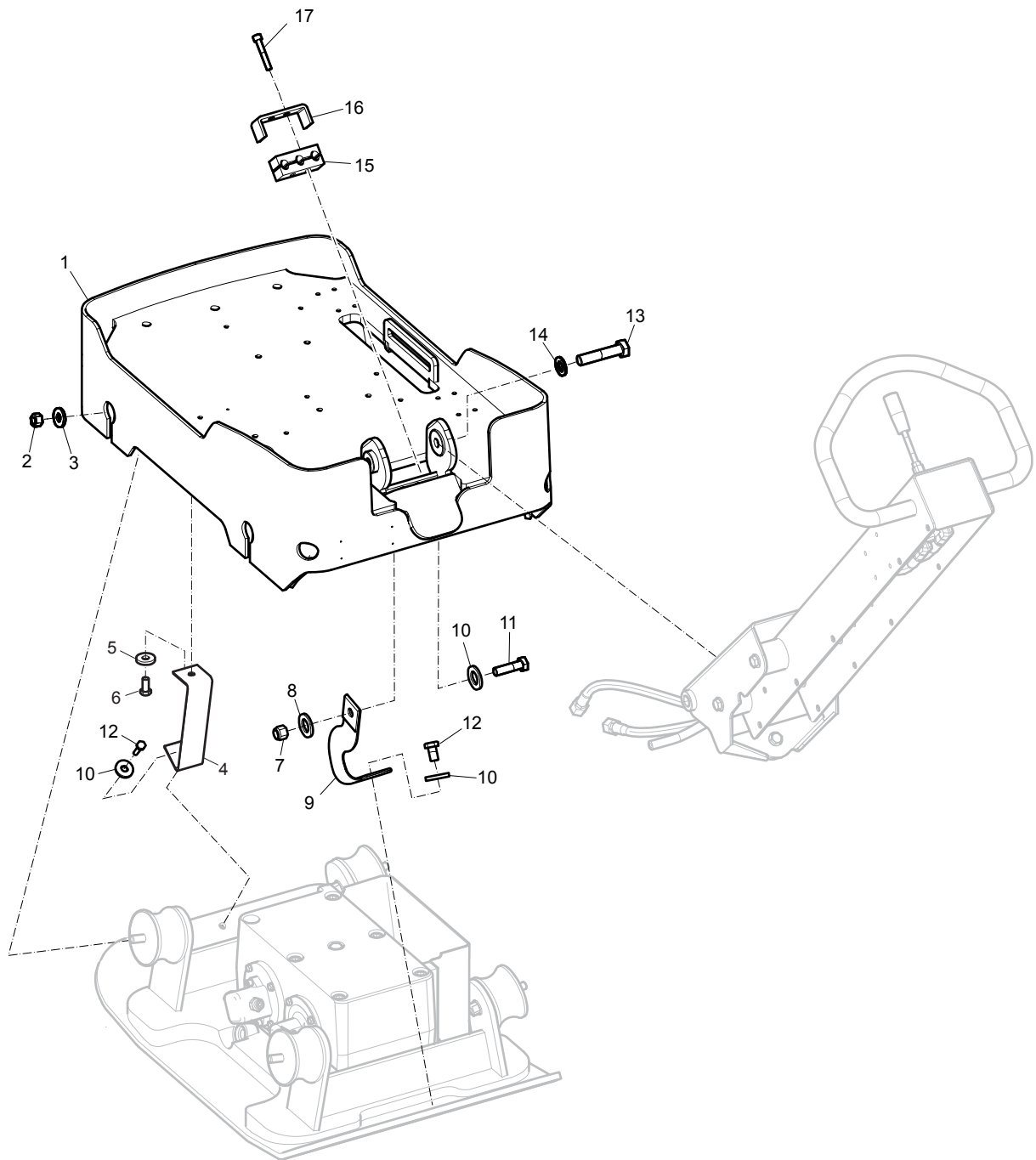

No.	Description	Remark	Quantity	Part number
1	Engine plate		1	3382 0101 69
2	Nut	M12 A3K	4	-
3	Washer	13 x 30 x 4 mm 0.51 x 1.18 x 0.16 in. 300 HV	4	-
4	Strap		1	3382 0100 59
5	Washer	13 x 36 x 6 mm 0.51 x 1.42 x 0.24 in. 300 HV	1	-
6	Screw	M12 x 25 mm 8.8 A3K	1	-
7	Lock nut	M12	1	-
8	Washer	13 x 24 x 2 mm 0.51 x 0.94 x 0.08 in. 300 HV	1	-
9	Strap		1	3382 0100 21
10	Washer	13 x 36 x 6 mm 0.51 x 1.42 x 0.24 in. 300 HV	3	-
11	Screw	M12 x 45 mm 8.8 A3K	2	-
12	Screw	M12 x 20 mm 8.8 A3K	2	-
13	Screw	M16 x 80 mm 10.9 GEOMET®	2	4700 9477 00
14	Washer	10.5 x 22 x 2 mm 0.41 x 0.87 x 0.08 in. 300 HV	4	-
15	Rubber block		1	4700 2805 34
16	Bracket		1	3382 0101 82
17	Screw	M8 x 50 mm 8.8 A2K	2	-

GEOMET is a registered trademark of Nof Metal Coatings North America Inc.

## Ground plate and eccentric element installation

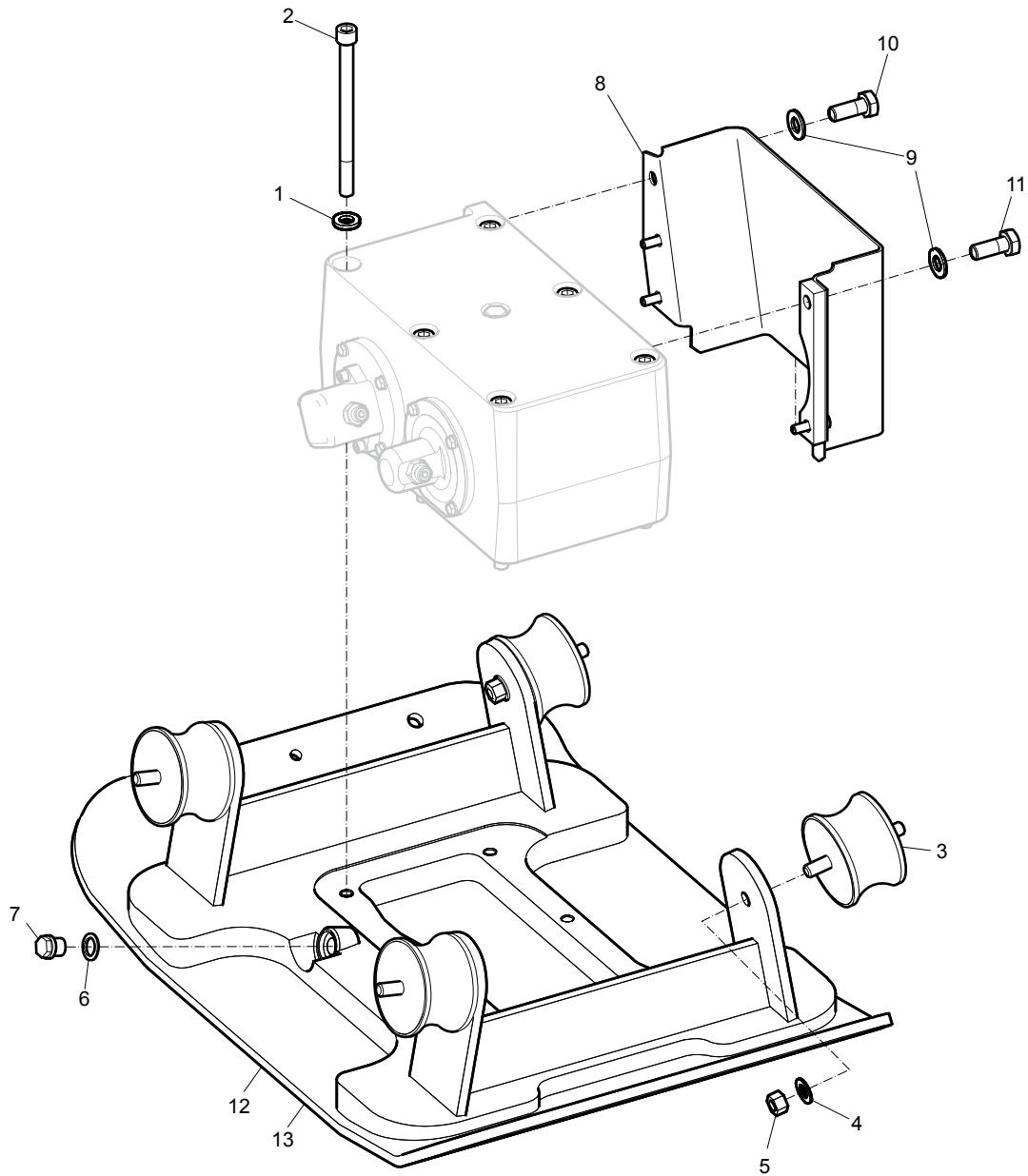

No.	Description	Remark	Quantity	Part number
1	Washer	13 x 24 x 6 mm 0.51 x 0.95 x 0.16 in. 300 HV	6	-
2	Screw	M12 x 160 mm 12.9 GEOMET®	6	4700 9294 54
3	Shock absorber		4	4700 2807 50
4	Washer	13 x 24 x 2 mm 0.51 x 0.94 x 0.08 in. 300 HV	4	-
5	Nut	M12 A3K	4	-
6	Washer	16.7 x 24 x 1.5 mm 0.66 x 0.94 x 0.06 in. TYPE A,M16	1	-
7	Oil drain plug		1	4700 2321 43
8	Belt guard		1	4700 3780 48
9	Washer	8.4 x16 x1.5 mm 0.33 x 0.63 x 0.06 in. 300 HV	5	-
10	Screw	M8 x 20 mm 8.8 A2K	3	4700 5000 53
11	Screw	M8 x 30 mm 8.8 A2K	2	-
12	Ground plate	500 mm 19.68 in.	1	4812 0706 74
13	Ground plate	600 mm 23.62 in.	1	4812 0700 76

GEOMET is a registered trademark of Nof Metal Coatings North America Inc.

# Block paving plate 500 mm (19.7 in.)

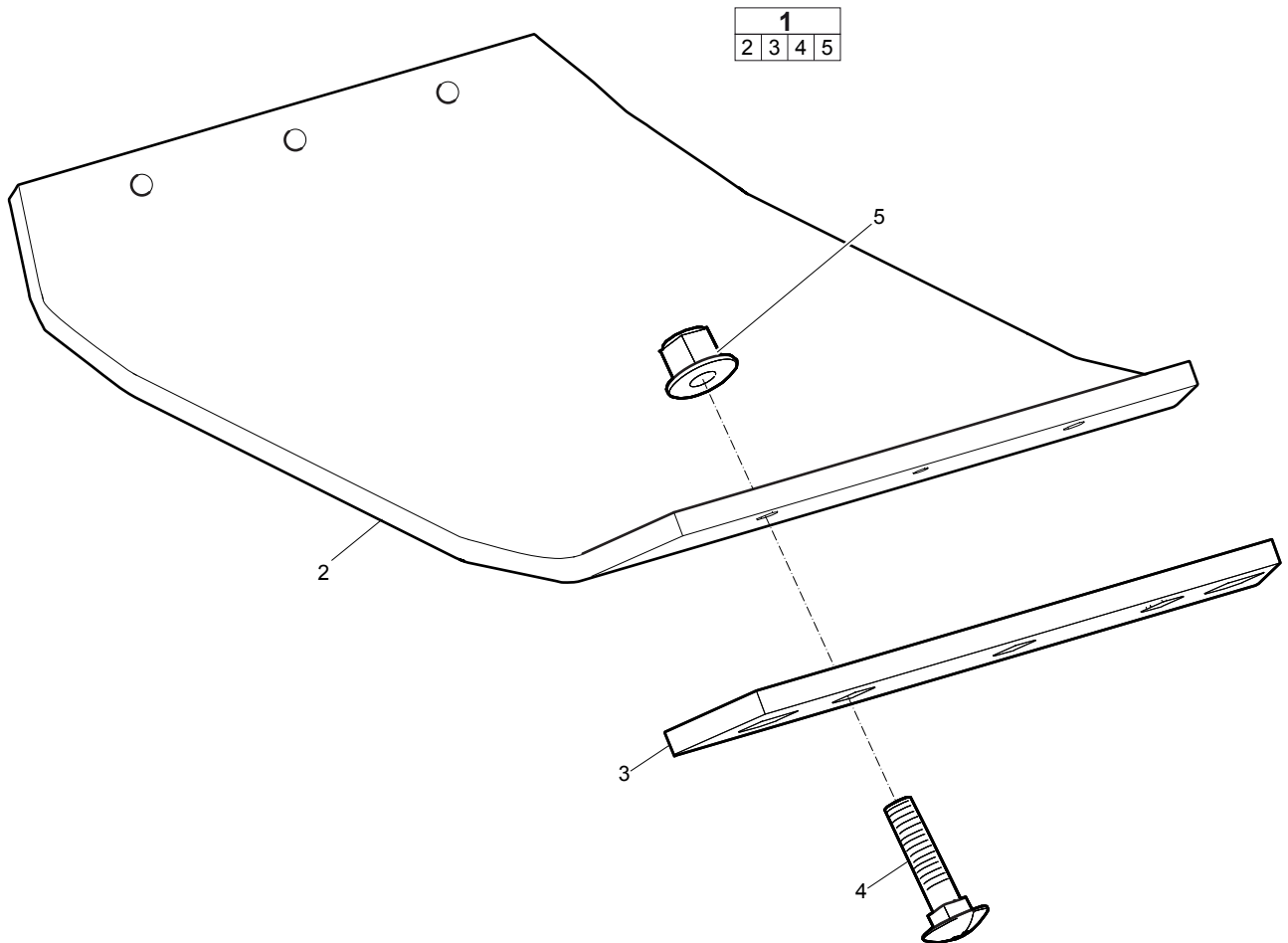

No.	Description	Remark	Quantity	Part number
1(2-5)	Block paving plate	500 mm 19.68 in.	1	4700 3944 61
2	Plate	Polyurethane	1	4700 3912 11
3	Bracket		2	4700 3819 54
4	Carriage screw	M10 x 45 mm 4.6	4	4700 9043 41
5	Nut	M10 x 1.5 mm A3K	4	-

# Block paving plate 600 mm (23.6 in.)

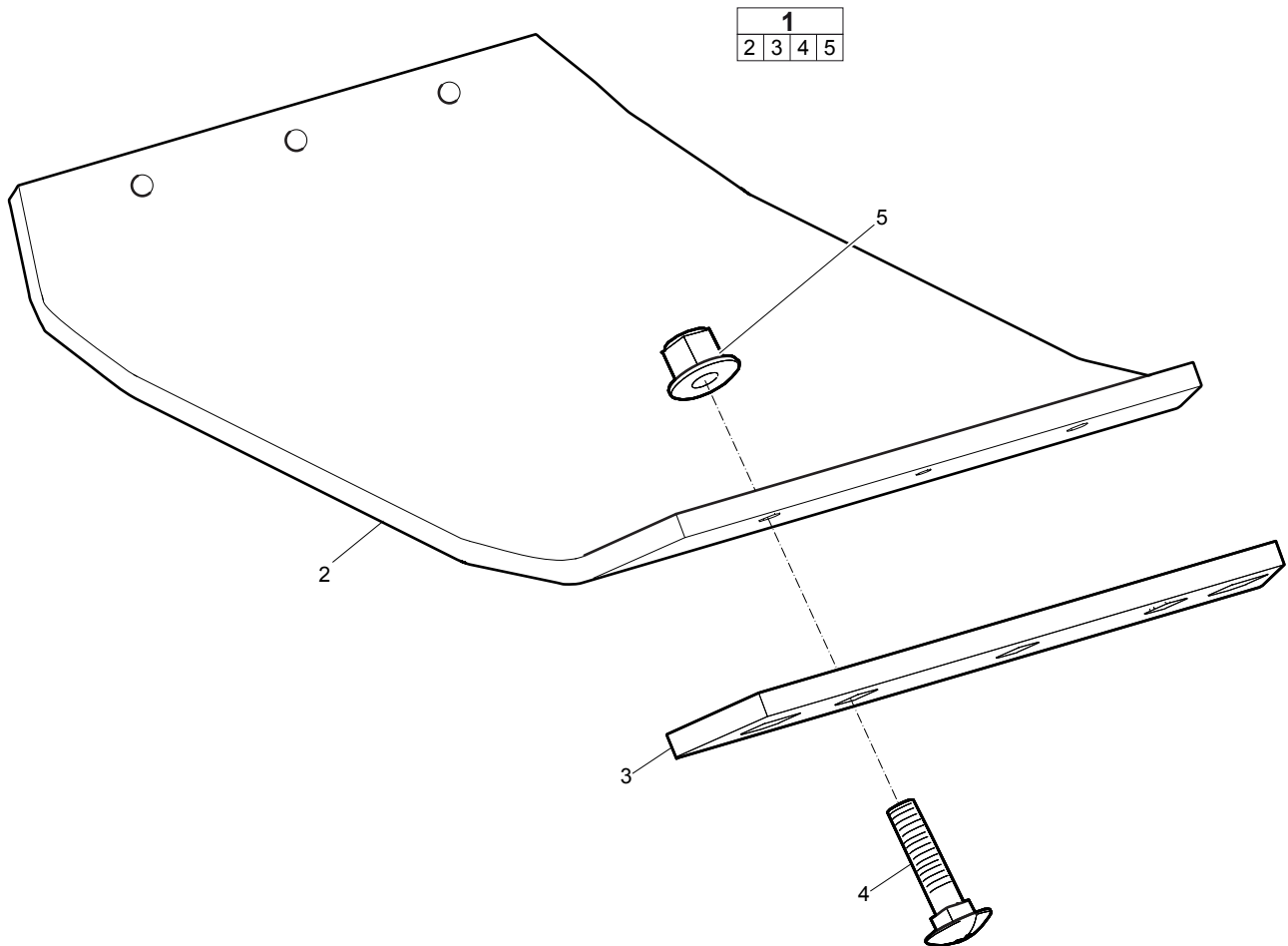



No.	Description	Remark	Quantity	Part number
1(2-5)	Block paving plate, complete	600 mm 23.62 in.	1	4700 3944 61
2	Plate	Polyurethane	1	4700 3912 12
3	Bracket		2	4700 3819 54
4	Carriage screw	M10 x 45 mm 4.6	4	4700 9043 41
5	Nut	M10 x 1.5 mm A3K	4	-

# Transport device

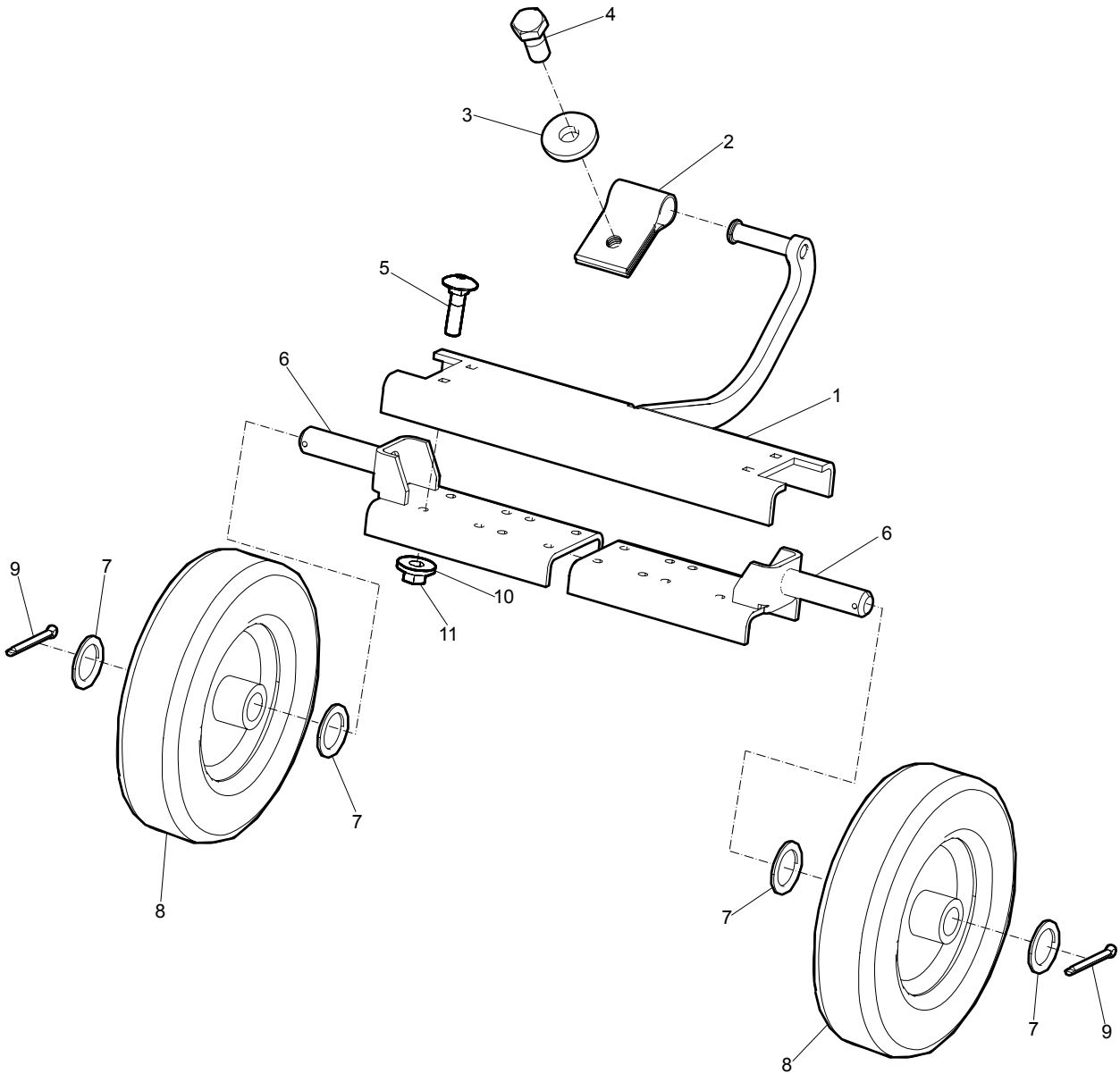

No.	Description	Remark	Quantity	Part number
1	Transport device		1	4700 3649 33
2	Strap		1	4700 2804 17
3	Washer	13 x 36 x 6 mm 0.51 x 1.42 x 0.24 in. 300 HV	1	-
4	Screw	M12 x 25 mm 8.8 A3K	1	-
5	Screw	M8 x 30 mm 8.8	4	-
6	Wheel bracket		2	4700 3949 85
7	Washer		4	4700 2710 32
8	Wheel		2	4700 3835 98
9	Split pin	4 x 40 mm 0.16 x 1.57 in.	2	4700 6300 15
10	Washer	8.4 x 22 x 3 mm 0.33 x 0.87 x 0.12 in. HV300	4	-
11	Nut	M8 A2K	4	-

# Eccentric element

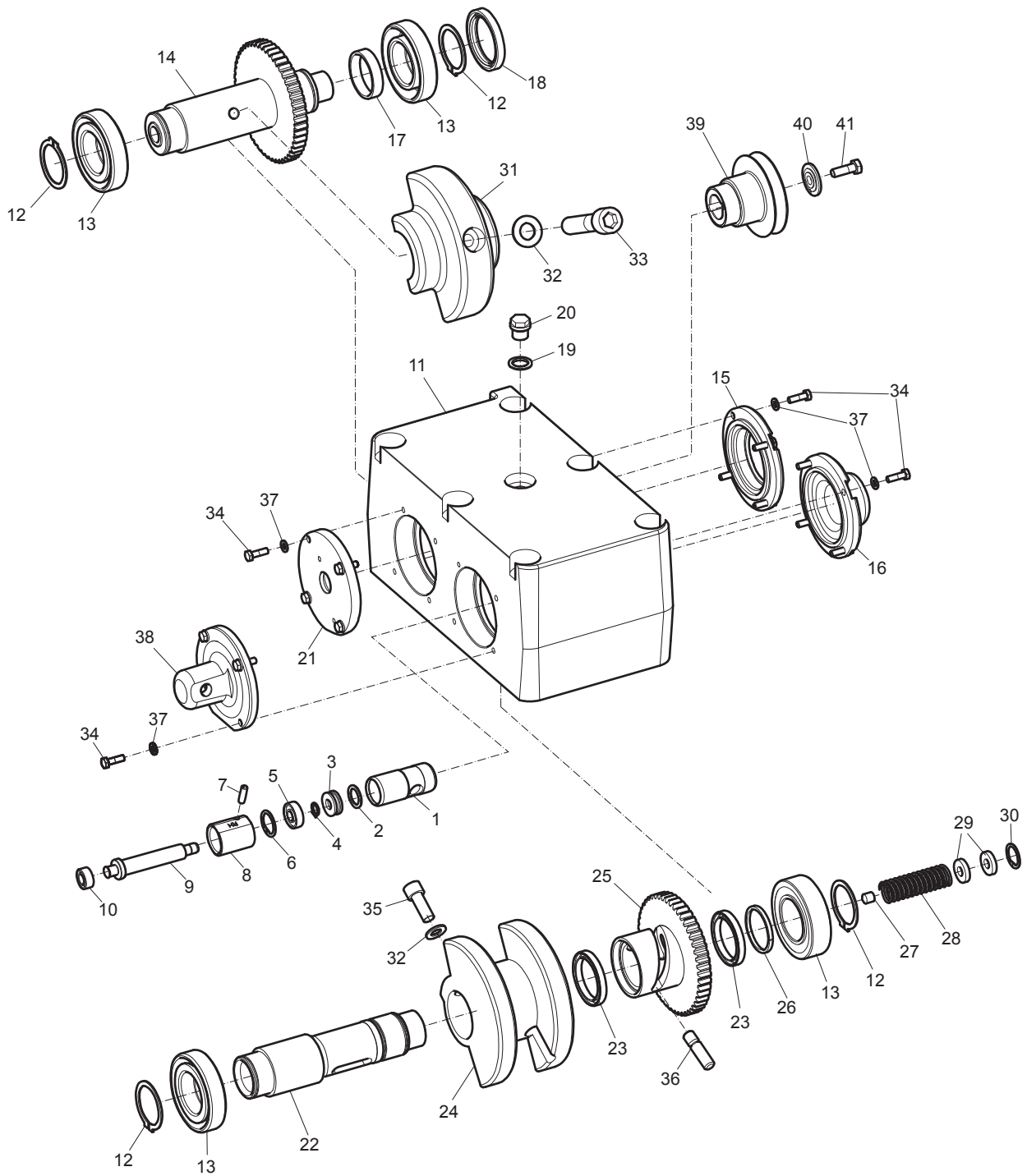

No.	Description	Remark	Quantity	Part number
1	Piston		1	4812 0700 53
2	Spring washer		1	4812 0703 63
3	Thrust ball bearing		1	4812 0703 62
4	Cap		1	4700 1500 02
5	Deep groove ball bearing		1	4812 0703 59
6	Retaining ring		1	4700 1510 39
7	Spring pin		1	4700 6290 62
8	Cap		1	4812 0700 97
9	Piston rod		1	4812 0700 51
10	Sealing		1	4700 2812 76
11	Eccentric housing		1	4700 3791 75
12	Retaining ring		4	4700 1500 17
13	Cylindrical roller bearing		4	4700 9033 63
14	Shaft		1	4700 3950 60
15	Cover		1	4700 3791 67
16	Cover		1	4812 0700 55
17	Spacer		1	4700 2806 45
18	Radial lip-type seal		1	4700 9287 94
19	Washer sealing	16.7 x 24 x 1.5 mm 0.66 x 0.94 x 0.06 in. TYPE A,M16	1	4700 1620 11
20	Steel plug threaded		1	4700 2321 43
21	Cover		1	4700 3791 68
22	Eccentric shaft		1	4812 0700 54
23	Deep groove ball bearing		2	4700 9292 87
24	Eccentric weight		1	4700 2806 69
25	Gear wheel		1	4712 0700 96
26	Spacer		1	4700 2806 46
27	Socket screw	M10 x 12 mm	1	-
28	Helical spring		1	4700 2806 77
29	Washer		2	4700 2806 48
30	Retaining ring		1	4700 1510 07
31	Eccentric		1	4700 2863 80
32	Steel plain washer	12 x 22 x 2 mm 0.47 x 0.87 x 0.08 in. 300 HV	2	-
33	Screw	M12 x 60 mm 10.9 GEOMET®	1	4700 7927 24
34	Screw	M6 x 20 mm 8.8 A2K	16	-
35	Screw	M12 x 30 mm 10.9 GEOMET®	1	4700 7927 23
36	Pin		1	4700 2806 44
37	Steel plain washer	6.4 x 12 x 1.5 mm 0.25 x 0.47 x 0.06 in. 300 HV	16	-
38	Hydraulic cylinder		1	4812 0700 50

GEOMET is a registered trademark of Nof Metal Coatings North America Inc.

## Engine installation, Honda

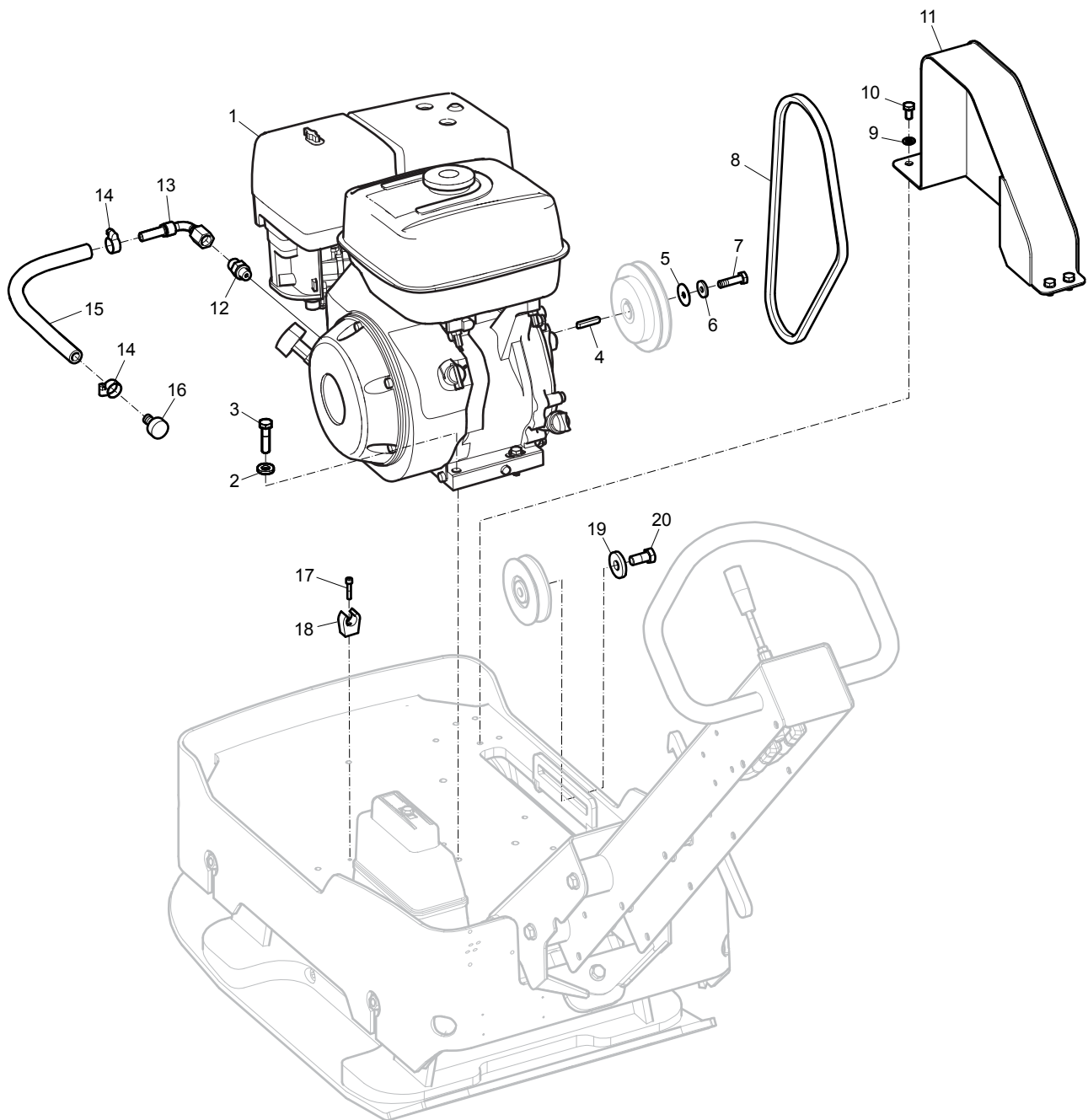

No.	Description	Remark	Quantity	Part number
1	Engine	Honda GX270 UT SWS4 SD	1	4700 2841 15
2	Washer	10.5 x 22 x 4 mm 0.33 x 0.87 x 0.16 in. 300 HV	4	-
3	Screw	M10 x 40 mm 8.8 A3K	4	-
4	Key		1	-
5	Washer	9 x 35 x 2 mm SR	1	-
6	Washer	8.4 x 26 x 4 mm 0.33 x 1.02 x 0.16 in. 300 HV	1	-
7	Screw	M8 x 30 mm 8.8 A2K	1	-
8	V-belt		1	4700 2813 36
9	Washer	8.4 x 16 x 1.5 mm 0.33 x 0.63 x 0.06 in. 300 HV	4	-
10	Screw	M8 x 16 mm 8.8 A2K	4	-
11	V-belt cover		1	3382 0101 66
12	Connector		1	4700 9032 68
13	Connector		1	4700 7920 99
14	Hose clamp		2	4700 3130 01
15	Hose		1	3382 0101 86
16	Plug		1	3382 0101 80
17	Screw	M5 x 25 mm 8.8 A2K	1	-
18	Ryw-clips		1	4700 2812 34
19	Washer	13 x 36 x 6 mm 0.51 x 1.42 x 0.24 in. 300 HV	1	-
20	Screw	M12 x 30 mm 8.8 A3K	1	-

# Engine installation, Hatz

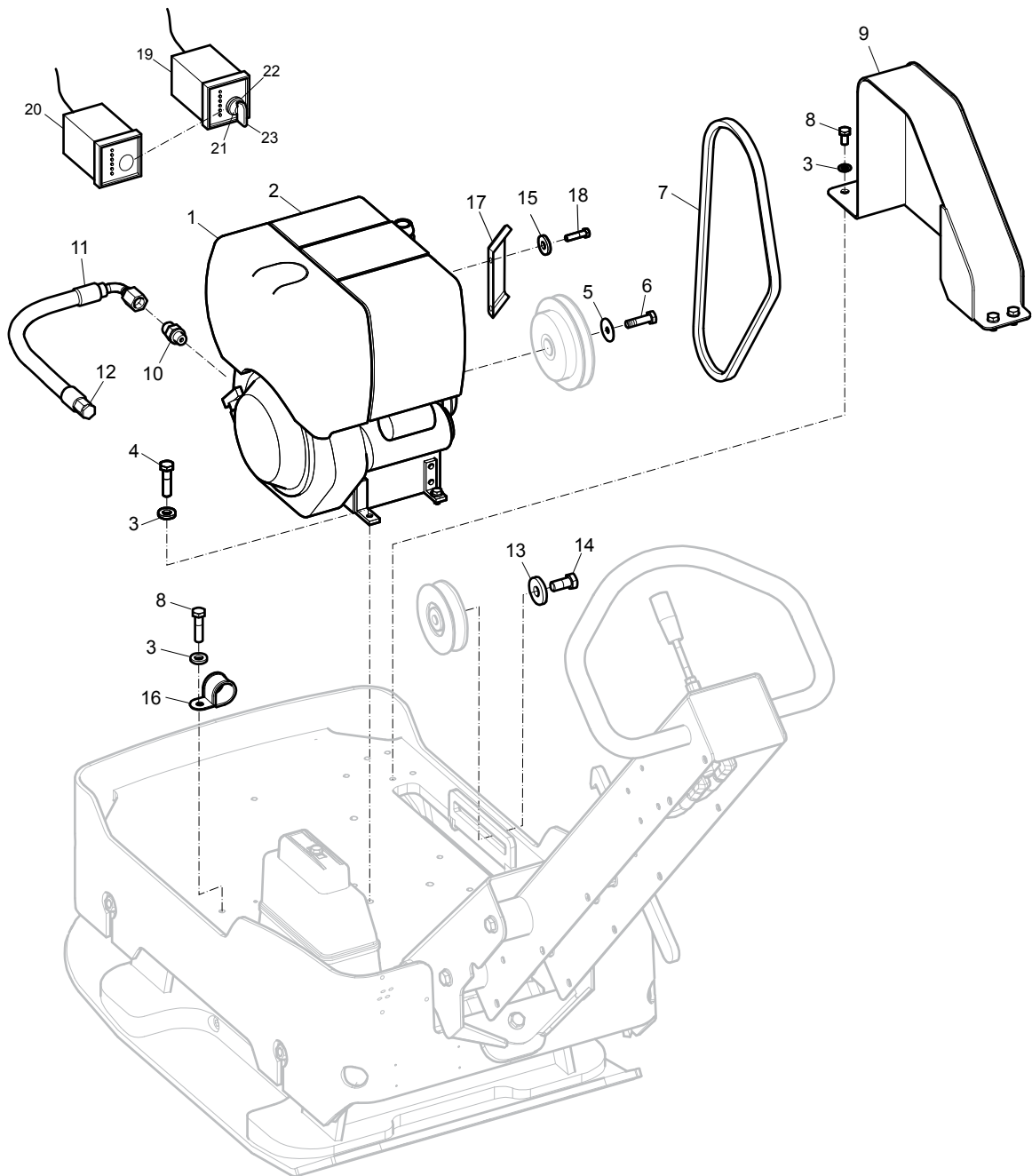



No.	Description	Remark	Quantity	Part number
1	Diesel engine	Hatz 1B20, manual start	1	4700 3778 94
2	Diesel engine	Hatz 1B20, electric start	1	4700 3778 93
3	Washer	8.4 x 16 x 1.5 mm 0.33 x 0.63 x 0.06 in. 300 HV	9	-
4	Screw	M8 x 20 mm 8.8 A2K	4	-
5	Washer	8.4 x 26 x 4 mm 0.33 x 1.02 x 0.16 in. 300 HV	1	-
6	Screw	M8 x 25 mm 8.8 A2K	1	-
7	V-belt		1	4700 2812 58
8	Screw	M8 x 16 mm 8.8 A2K	5	-
9	V-belt cover		1	3382 0101 67
10	Connector		1	4700 9039 25
11	Hydraulic hose		1	4700 4825 39
12	Plug		1	4700 2320 95
13	Washer	13 x 30 x 4 mm 0.51 x 1.18 x 0.16 in. 300 HV	1	-
14	Screw		1	-
15	Washer	6.4 x 12 x 1.5 mm 0.25 x 0.47 x 0.06 in. 300 HV	2	4700 9042 28
16	Clamp		1	4700 9210 44
17	Deflector		1	4700 3905 60
18	Screw	M6 x 16 mm 8.8 A2K	2	4700 5080 02
19	Control box	Standard	1	4700 3780 71
20	Control box	Option	1	4700 3780 72
21	Dirt shield		1	4700 3790 28
22	Ignition switch		1	4700 9381 46
23	Ignition key		1	4700 9380 86

# Centrifugal clutch, Honda

1													
2	3	4	5	6	7	8	9	10	11	12	13	14	

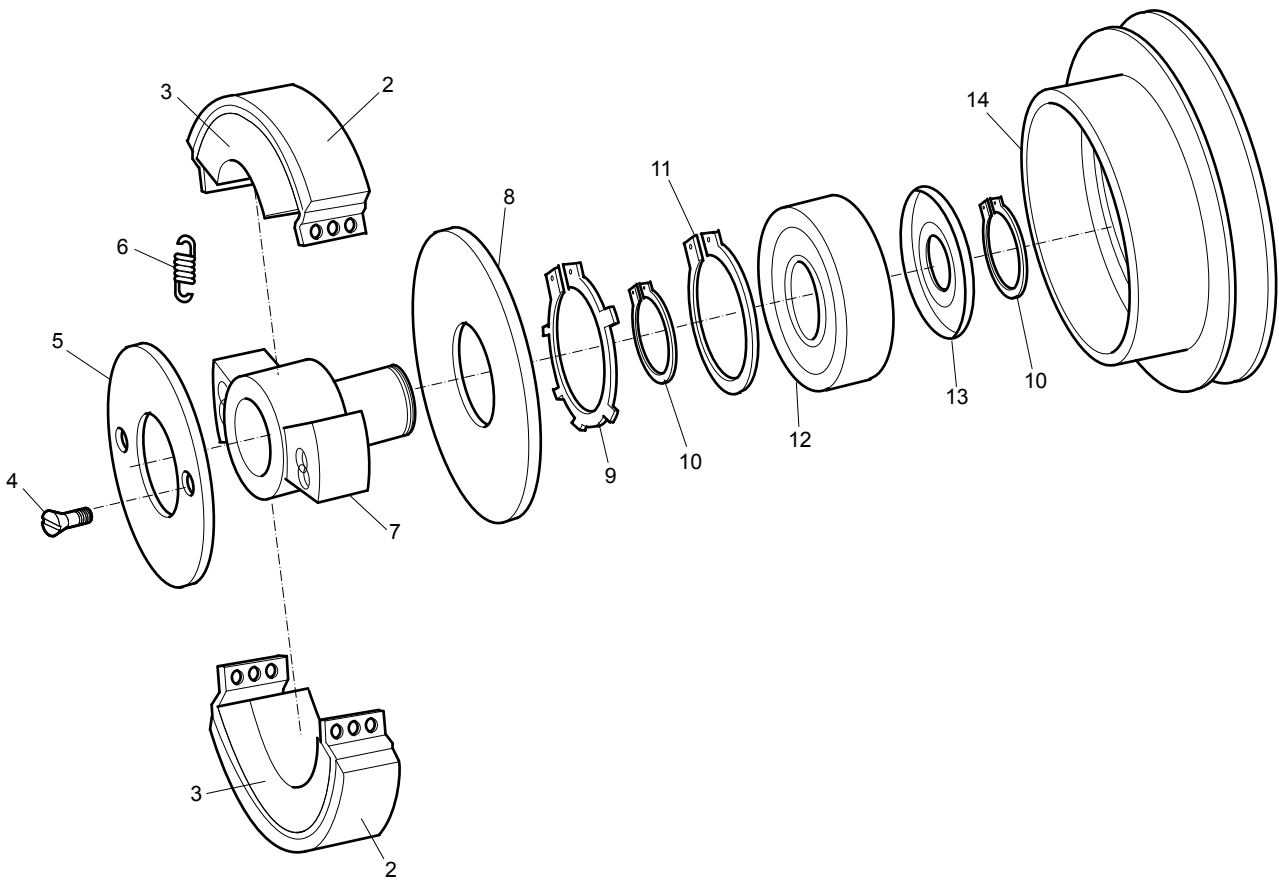

No.	Description	Remark	Quantity	Part number
1(2-14)	Centrifugal clutch, complete		1	4700 3779 88
2	Clutch lining		2	4700 9452 60
3	Clutch weight		2	3382 0101 85
4	Screw		2	4700 5350 02
5	Cover		1	3382 0101 84
6	Spring		4	4700 9375 27
7	Hub		1	4700 9451 11
8	Cover		1	4700 2398 57
9	Retaining ring		1	4700 2395 39
10	Snap ring		2	4700 9387 26
11	Retaining ring		1	4700 9387 25
12	Ball bearing		1	4700 9387 24
13	Nilos ring		1	4700 1340 36
14	V-belt pulley		1	4700 9451 10

# Centrifugal clutch, Hatz

1													
2	3	4	5	6	7	8	9	10	11	12	13	14	

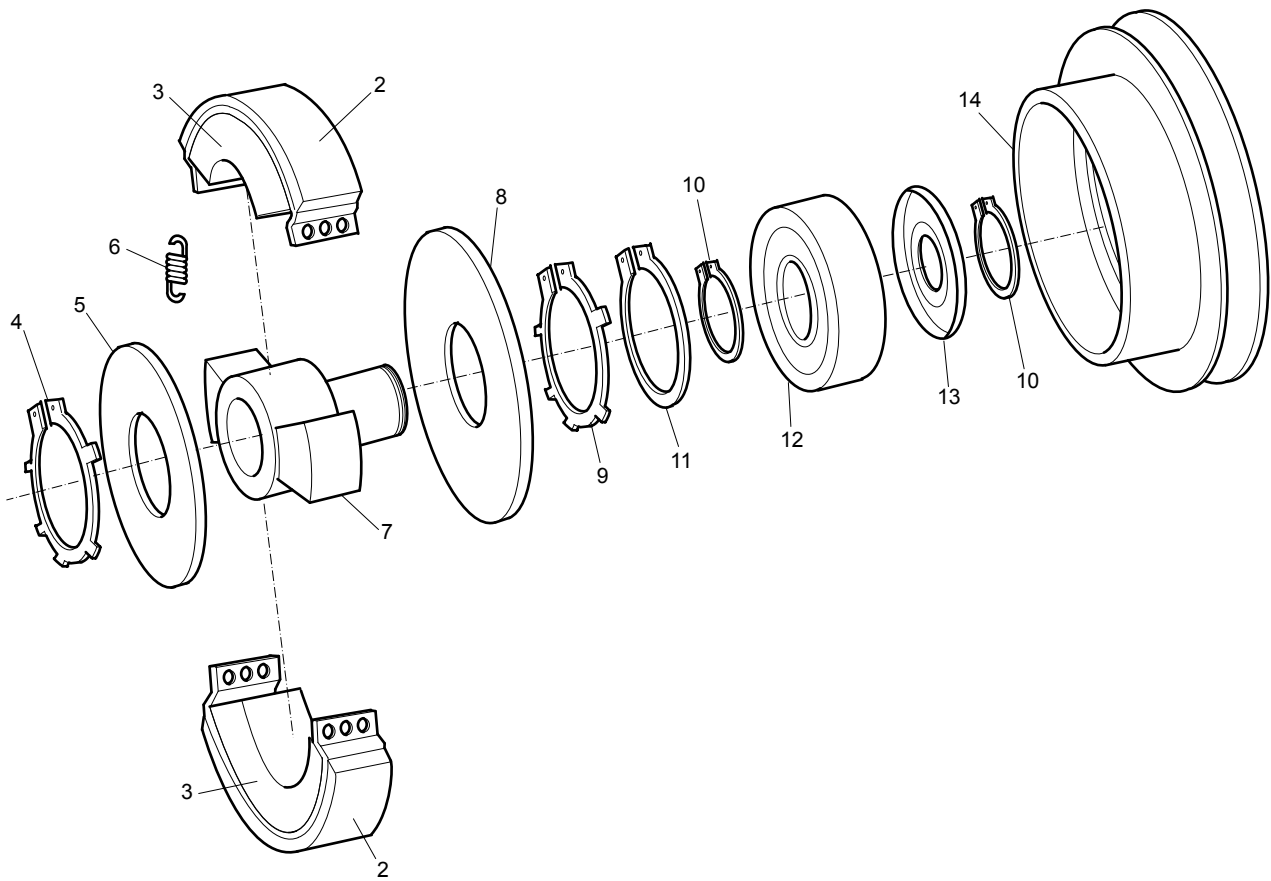

No.	Description	Remark	Quantity	Part number
1(2-14)	Centrifugal clutch, complete		1	4700 3780 33
2	Clutch lining		2	4700 9456 12
3	Clutch weight		2	3382 0101 85
4	Retaining ring		1	4700 2397 34
5	Cover		1	4700 2397 68
6	Spring		4	4700 9375 27
7	Hub		1	4700 9370 31
8	Cover		1	4700 2398 57
9	Retaining ring		1	4700 2395 39
10	Snap ring		2	4700 9387 26
11	Retaining ring		1	4700 9387 25
12	Ball bearing		1	4700 9387 24
13	Nilos ring		1	4700 1340 36
14	V-belt pulley		1	4700 9370 29

## Belt tightner

---

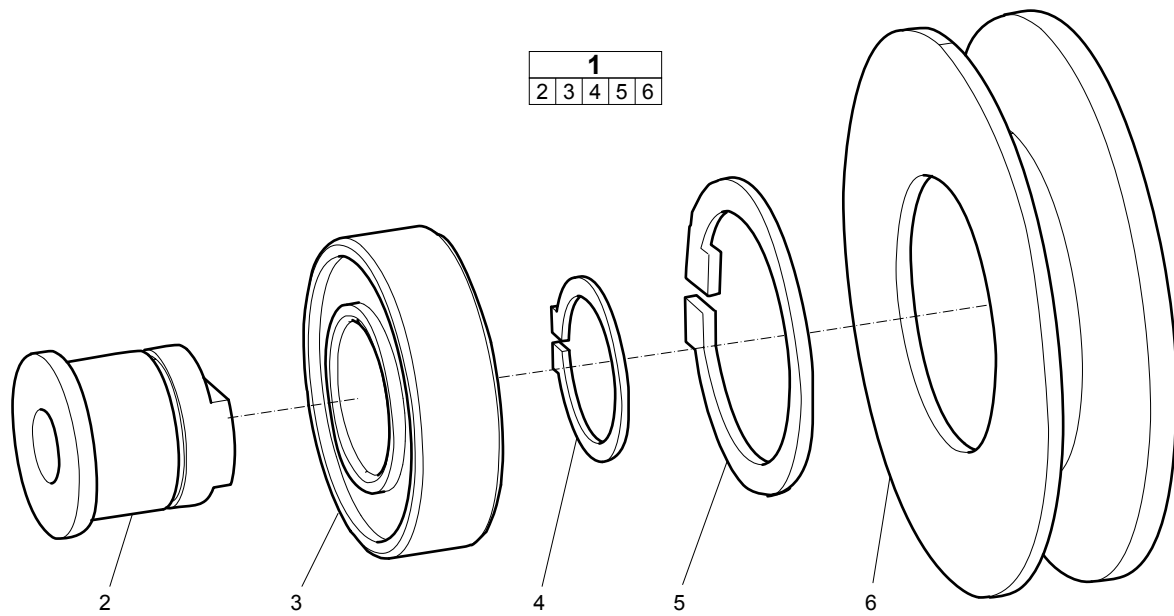

No.	Description	Remark	Quantity	Part number
1(2-6)	Belt tightner, complete		1	4700 2808 35
2	Shaft		1	4700 2808 37
3	Ball bearing		1	4700 1111 14
4	Snap ring		1	4700 1600 09
5	Snap ring		1	4700 1510 17
6	V-belt pulley		1	4700 2808 36

# Hydraulic system

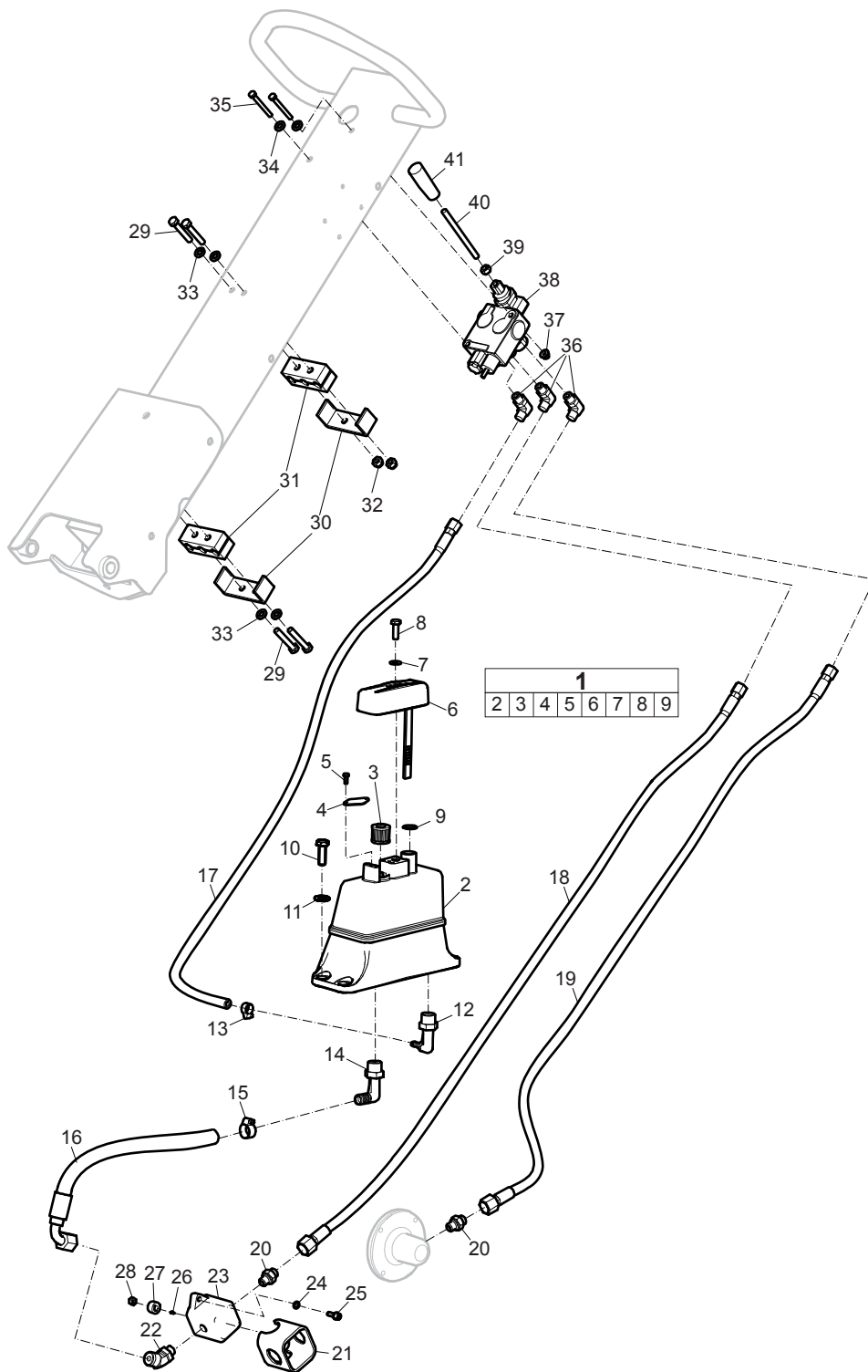



No.	Description	Remark	Quantity	Part number
1(2-9)	Hydraulic oil tank, complete		1	4700 3766 76
2	Tank		1	-
3	Air filter		1	4700 3815 66
4	Holder		1	4700 3815 63
5	Screw	K50 x 12 mm Type KX-PT	2	-
6	Cover		1	4700 3813 85
7	Washer		1	4700 9042 29
8	Screw	M8 x 25 mm 8.8 A2K	1	4700 5000 21
9	O-ring	15.3 x 2.4 mm 0.64 x 0.09 in. (Shore 70)	1	4700 1601 10
10	Screw	M10 x 30 mm 8.8 A3K	4	-
11	Washer	10.5 x 22 x 2 mm 0.41 x 0.87 x 0.08 in. 300 HV	4	-
12	Adaper		1	4700 3766 74
13	Hose clamp		1	4700 3130 08
14	Adapter		1	4700 3766 75
15	Hose clamp		1	4700 3130 03
16	Hydraulic hose		1	4700 3792 35
17	Hydraulic hose	Connected to port "T"	1	4700 3796 59
18	Hydraulic hose	Connected to port "P"	1	4700 4838 99
19	Hydraulic hose	Connected to port "A"	1	4700 4839 00
20	Straight connector		2	4700 7915 37
21	Cover		1	4700 2805 40
22	Elbow		1	4700 7922 53
23	Hydraulic pump		1	4700 3835 62
24	Washer	6.4 x 12 x 1.5 mm 0.25 x 0.47 x 0.06 in. 300 HV	1	-
25	Screw	M6 x 20 mm 8.8 A2K	2	-
26	Key	Supplied with hydraulic pump	1	-
27	Sleeve		1	4700 9288 94
28	Nut	Supplied with hydraulic pump	1	-
29	Screw	M8 x 50 mm 8.8 A2K	4	4700 5000 25
30	Bracket		2	3382 0101 82
31	Rubber block		2	4700 2805 34
32	Lock nut		2	4700 5860 03
33	Washer		4	4700 9042 29
34	Washer	6.4 x 12 x 1.5 mm 0.25 x 0.47 x 0.06 in. 300 HV	2	-
35	Screw	M6 x 55 mm 8.8 A2K	2	-
36	Elbow	90°	3	4700 7913 97
37	Nut	M6 x 1 mm A2K	1	-
38	Hydraulic valve		1	4700 2829 93
39	Nut	M8 A2K	1	-
40	Rod		1	4700 3904 50
41	Grab handle		1	4700 9038 21

## Battery installation

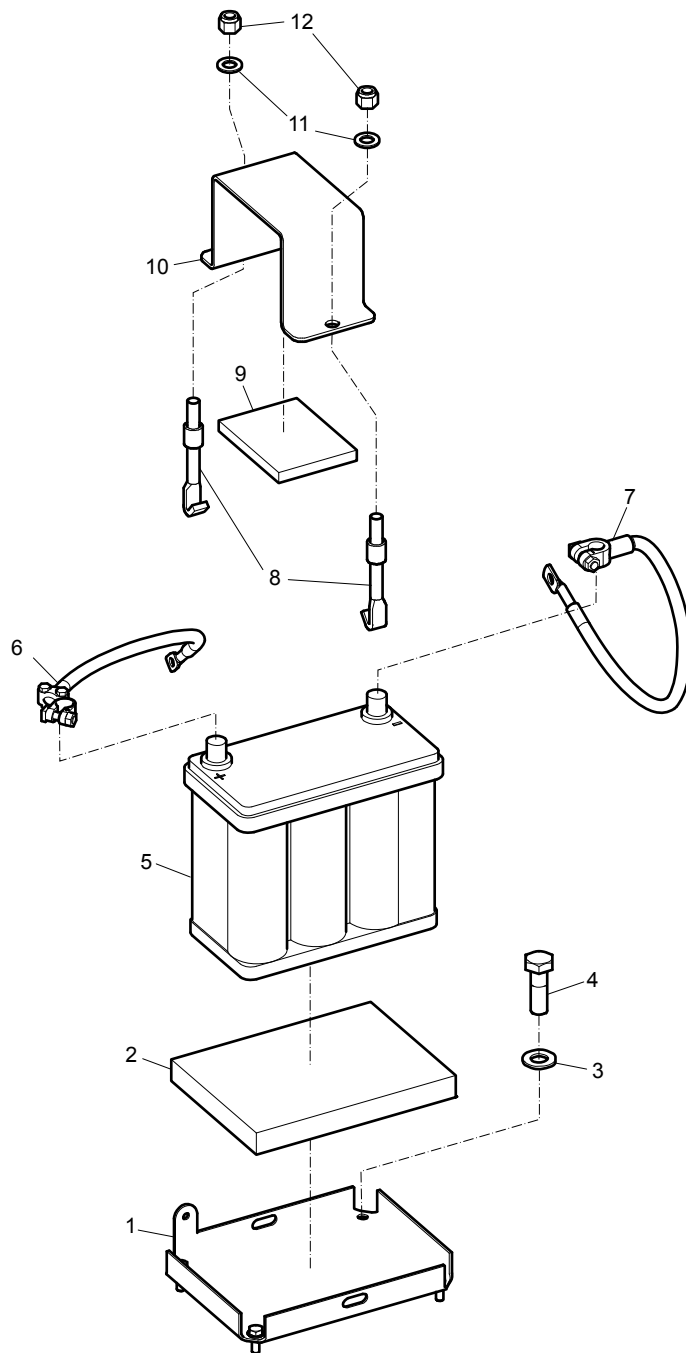

No.	Description	Remark	Quantity	Part number
1	Plate		1	4700 3792 43
2	Insulation		1	4700 3790 61
3	Washer	8.4 x16 x1.5 mm 0.33 x 0.63 x 0.06 in. 300 HV	4	-
4	Screw	M8 x 25 mm 8.8 A2K	4	-
5	Battery	12V 41Ah	1	4700 3787 19
6	Battery cable	Connected to positive terminal of battery	1	4700 7922 34
7	Battery cable	Connected to negative terminal of battery	1	4700 7917 52
8	Battery screw		2	4700 3938 49
9	Insulation		1	4700 3790 62
10	Holder		1	4700 3938 48
11	Washer	13 x 24 x 2 mm 0.51 x 0.98 x 0.08 in. 300 HV	2	-
12	Screw	M12X20H 8.8 A3K	2	-

# Handle

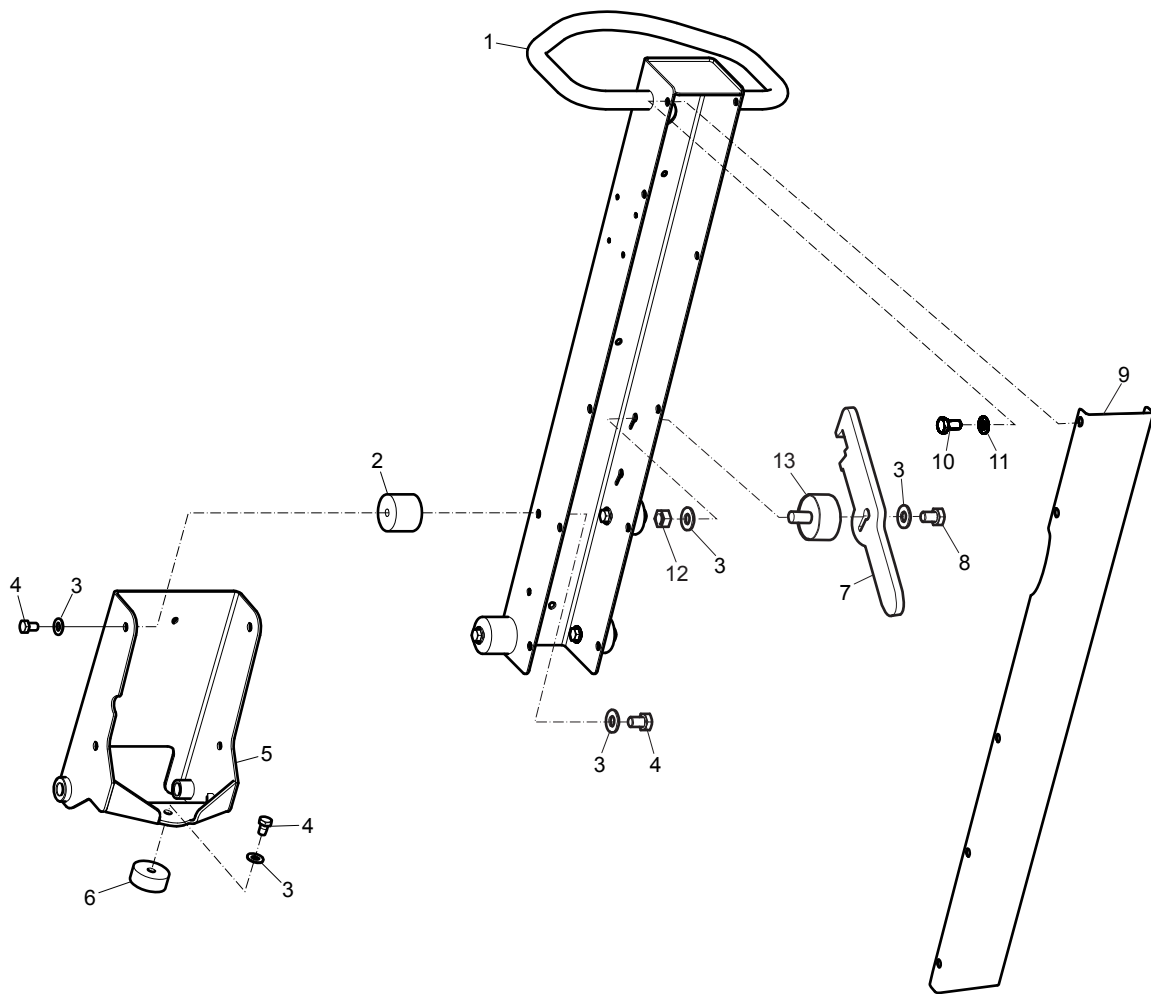

No.	Description	Remark	Quantity	Part number
1	Handle		1	3382 0101 70
2	Shock absorber		4	3382 0101 83
3	Steel plain washer	10.5 x 22 x 2 mm 0.41 x 0.87 x 0.08 in. 300 HV	11	-
4	Screw	M10 x 16 mm 8.8 A3K	9	-
5	Bracket		1	3382 0101 71
6	Shock absorber		1	4700 7913 73
7	Hook		1	4700 3790 04
8	Screw	M10 x 20 mm 8.8 A3K	1	-
9	Cover		1	3382 0101 87
10	Screw	M8 x 16 mm 8.8 A2K	10	-
11	Steel plain washer	8.4 x 16 x 1.5 mm 0.33 x 0.63 x 0.06 in. 300 HV	10	-
12	Nut	M10 A3K	1	-
13	Shock absorber		1	4700 3853 87

## Throttle control, Honda

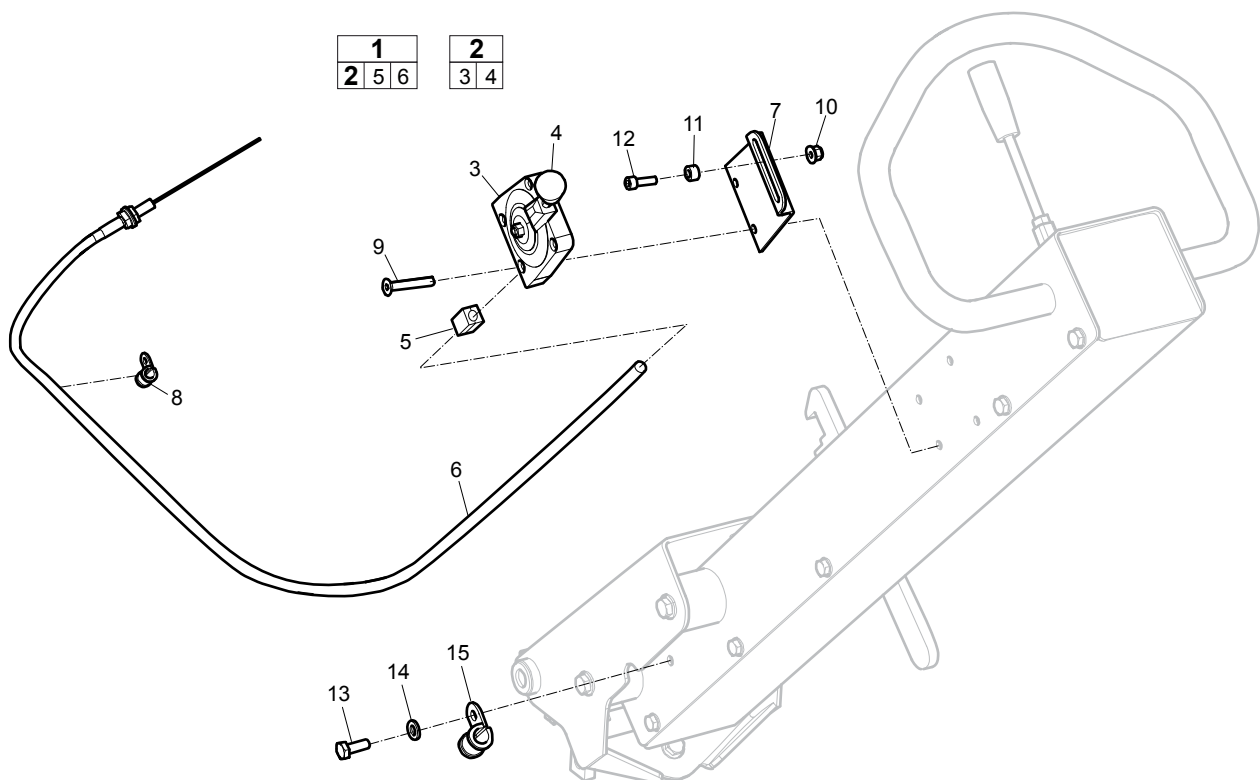

No.	Description	Remark	Quantity	Part number
1(2,5-6)	Throttle control, complete		1	4700 2864 52
2(3-4)	Throttle handle, complete		1	4700 4550 19
3	Throttle		1	-
4	Knob		1	4700 9456 55
5	Square nipple		1	4700 2384 43
6	Throttle cable		1	4700 2864 45
7	Bracket		1	4700 2843 65
8	Throttle		1	-
9	Screw	M5 x 30 mm A2-70	4	-
10	Nut	M6 x 1 mm A2K	1	-
11	Spacer		1	4700 3944 17
12	Screw	M6 x 20 mm 8.8 A2K	1	-
13	Screw	M6 x 16 mm 8.8 A2K	1	-
14	Washer	6.4 x 12 x 1.5 mm 0.25 x 0.47 x 0.06 in. 300 HV	1	4700 9042 28
15	Clamp	10 x 6.4 x 15 mm 0.40 x 0.25 x 0.60 in.	1	4700 7913 41

# Throttle control, Hatz

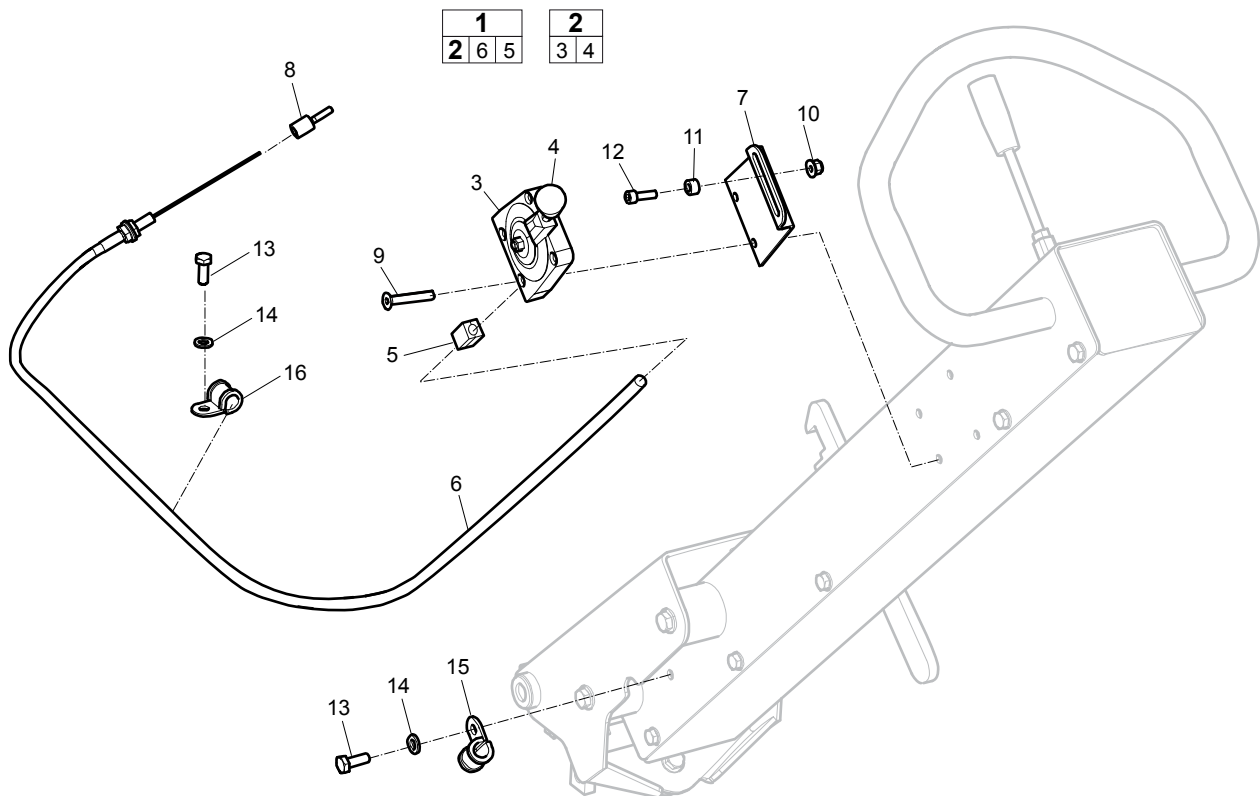



No.	Description	Remark	Quantity	Part number
1(2,5-6)	Throttle control, complete		1	4700 3793 00
2(3-4)	Throttle handle, complete		1	4700 4550 19
3	Throttle part		1	-
4	Knob		1	4700 9456 55
5	Square nipple		1	4700 2384 43
6	Throttle cable		1	4700 3792 99
7	Bracket		1	4700 2843 65
8	Nipple		1	4700 2841 07
9	Screw	M5 x 30 mm A2-70	4	-
10	Nut	M6 x 1 mm A2K	1	-
11	Spacer		1	4700 3944 17
12	Screw	M6 x 20 mm 8.8 A2K	1	-
13	Screw	M6 x 16 mm 8.8 A2K	2	-
14	Washer	6.4 x 12 x 1.5 mm 0.25 x 0.47 x 0.06 in. 300 HV	2	-
15	Clamp	10 x 6.4 x 15 mm 0.40 x 0.25 x 0.60 in.	1	4700 7913 41
16	Clamp	16 x 6.4 x 15 mm 0.63 x 0.25 x 0.60 in.	1	4700 9210 31

# Labels, Honda

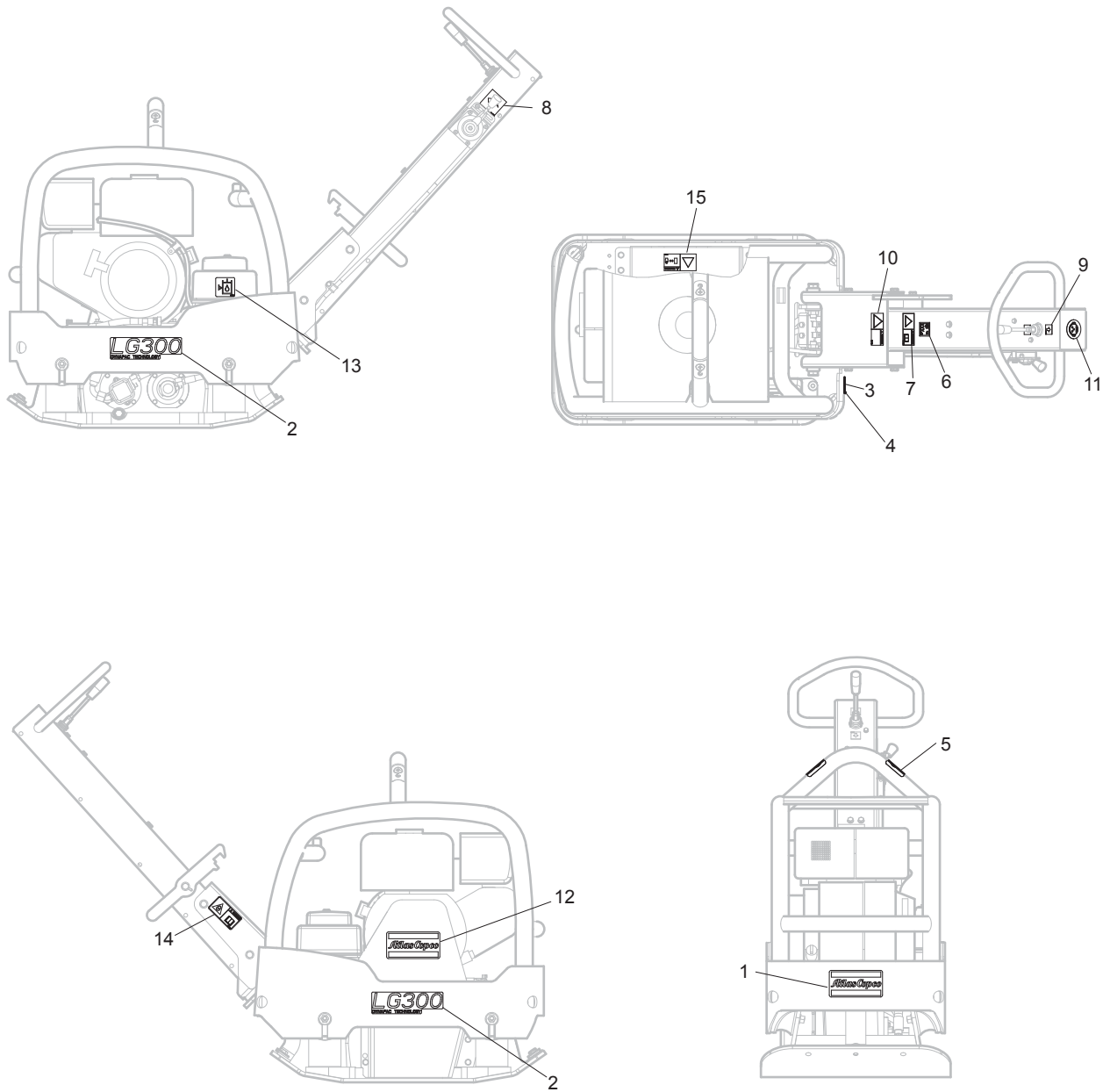

No.	Description	Remark	Quantity	Part number
1	Product label	"Atlas Copco"	1	3382 0100 78
2	Product label	"LG 300"	2	3382 0101 74
3	Data plate		1	-
4	Drive screw		4	-
5	Label	Lift point	2	4700 3875 87
6	Noise level label		1	4700 7912 96
7	Safety label	Read instruction manual	1	4700 9046 80
8	Label	Engine speed	1	4700 2842 85
9	Label	Direction	2	4700 2842 78
10	Safety label	Crush zone	1	4700 9047 85
11	Label	Ear protection	1	4700 2818 98
12	Product label	"Atlas Copco"	1	3382 0101 75
13	Label	Hydraulic oil level	1	4700 2723 73
14	Safety label	Lock handle	1	4700 9082 29
15	Safety label	Rotating V-belts	1	4700 9038 32

# Labels, Hatz

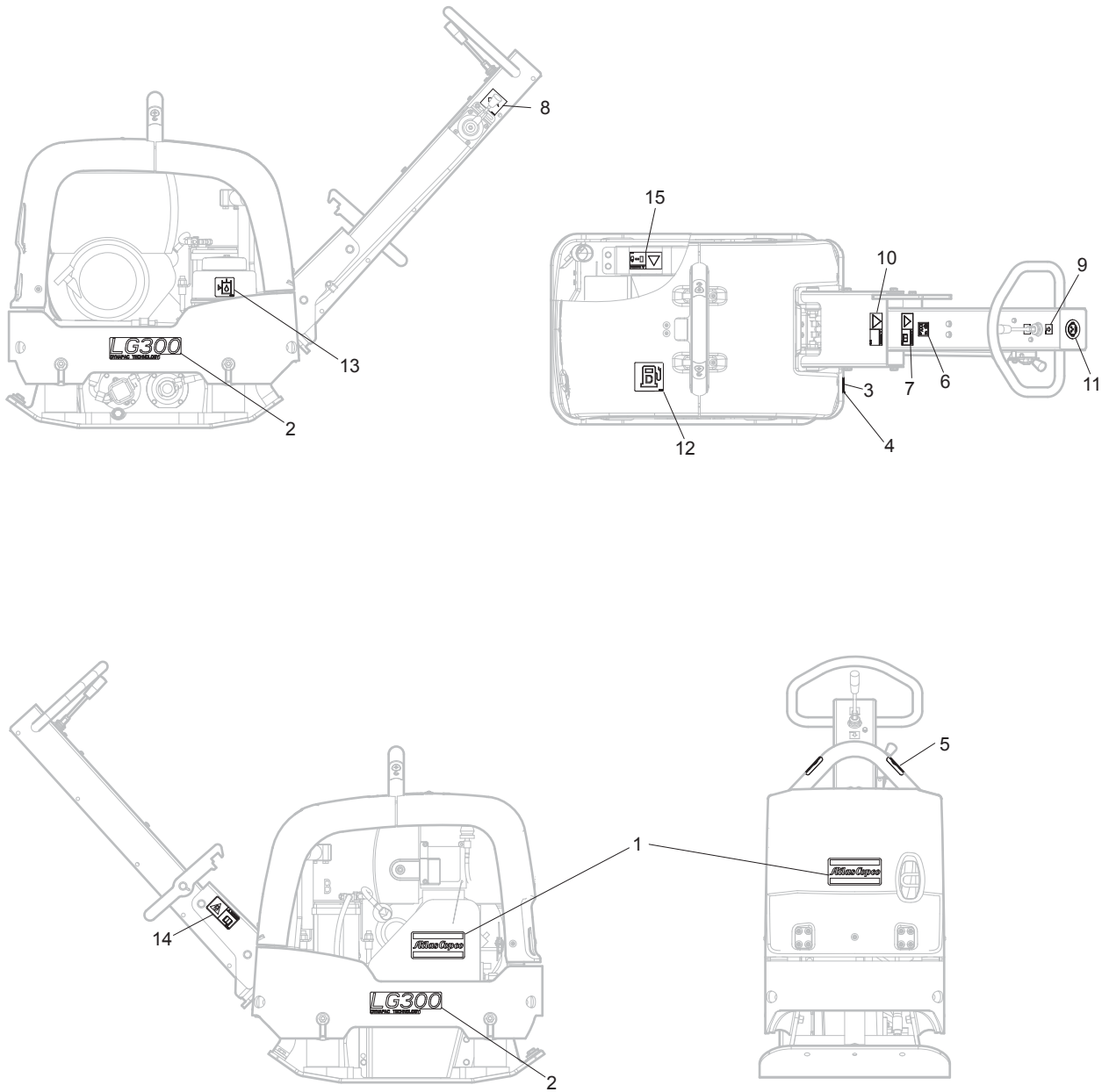

No.	Description	Remark	Quantity	Part number
1	Product label	"Atlas Copco"	2	3382 0100 78
2	Product label	"LG 300"	2	3382 0101 74
3	Data plate		1	-
4	Drive screw		4	-
5	Label	Lift point	2	4700 3875 87
6	Noise level label		1	4700 7912 96
7	Safety label	Read instruction manual	1	4700 9046 80
8	Label	Engine speed	1	4700 2842 85
9	Label	Direction	2	4700 2842 78
10	Safety label	Crush zone	1	4700 9047 85
11	Label	Ear protection	1	4700 2818 98
12	Label	Diesel fuel	1	4700 9916 58
13	Label	Hydraulic oil level	1	4700 2723 73
14	Safety label	Lock handle	1	4700 9082 29
15	Safety label	Rotating V-belts	1	4700 9038 32

## Kits

### One year service kit, Honda

#### One year service kit

Part number 3382 1000 25

Description	Remark	Quantity	Part number
Air filter		5	4700 9374 99
Gasket	For oil dipstick.	1	4700 2383 03
Starting rope		1	4700 2393 74
Spark plug		1	4700 9242 42
V-belt	See section "Engine installation".	1	4700 2813 36
Gasket	For valve cover.	1	3382 1000 22

### One year service kit, Hatz

#### One year service kit

Part number 3382 1000 26

Description	Remark	Quantity	Part number
Air filter		5	4700 9370 13
Fuel filter		5	4700 9396 18
Gasket	For oil drain plug.	1	4700 9370 03
Starting rope		1	4700 9369 89
V-belt	See section "Engine installation".	1	4700 2812 58
Gasket	For valve cover.	1	4700 9504 24

## Shock absorber repair kit

Description	Remark	Quantity	Part number
<b>Shock absorber repair kit</b>		1	3382 1000 31
Shock absorber	For ground plate .See section "Ground plate and eccentric element installation".	4	4700 2807 50
Nut	M12 A3K See section "Ground plate and eccentric element installation".	8	-
Washer	13 x 30 x 4 mm 0.51 x 1.18 x 0.16 in. 300 HV See section "Engine plate".	4	-
Washer	13 x 24 x 2 mm 0.51 x 0.94 x 0.08 in. 300 HV See section "Ground plate and eccentric element installation".	4	-
Shock absorber	For handle. See section "Handle".	4	3382 0101 83
Screw	M10 x 16 mm 8.8 A3K See section "Handle".	4	-
Washer	10.5 x 22 x 2 mm 0.41 x 0.87 x 0.08 in. 300 HV See section "Handle".	4	-
Shock absorber	See section "Handle".	1	4700 7913 73
Shock absorber	See section "Handle".	1	4700 3853 87

## Eccentric element repair kit

Description	Remark	Quantity	Part number
<b>Eccentric element repair kit</b>		1	3382 1000 36
Ball bearing	See section "Eccentric element".	4	4700 9033 63
Sealing	See section "Eccentric element".	1	4700 9287 94
Ball bearing	See section "Eccentric element".	2	4700 9292 87
Retainer ring	See section "Eccentric element".	1	4700 1510 07
Washer	6.4 x 12 x 1.5 mm 0.25 x 0.47 x 0.06 in. 300 HV See section "Eccentric element".	16	-
Screw	M6 x 20 mm 8.8 A2K See section "Eccentric element".	16	-
Sealing compound	See section "Eccentric element".	1	4700 9299 06
Copper washer	16.7 x 24 x 1.5 mm 0.66 x 0.94 x 0.06 in. TYPE A, M16 See section "Eccentric element".	1	-

## Forward and reverse piston repair kit

Description	Remark	Quantity	Part number
<b>Forward and reverse piston repair kit</b>		1	3382 1000 34
Sealing	See section "Eccentric element".	1	4700 2812 76
Piston rod	See section "Eccentric element".	1	4812 0700 51
Retainer ring	See section "Eccentric element".	1	4700 1510 39
Ball bearing	See section "Eccentric element".	1	4812 0703 59
Retainer ring	See section "Eccentric element".	1	4700 1500 02
Ball bearing	See section "Eccentric element".	1	4812 0703 62
Spring washer	See section "Eccentric element".	1	4812 0703 63
Cylinder	See section "Eccentric element".	1	4812 0700 50
Spirol pin	See section "Eccentric element".	1	4700 6290 62
Washer	6.4 x 12 x 1.5 mm 0.25 x 0.47 x 0.06 in. 300 HV See section "Eccentric element".	4	-
Screw	M6 x 20 mm 8.8 A2K See section "Eccentric element".	4	-

## Block paving plate kit 500 mm (19.7 in.)

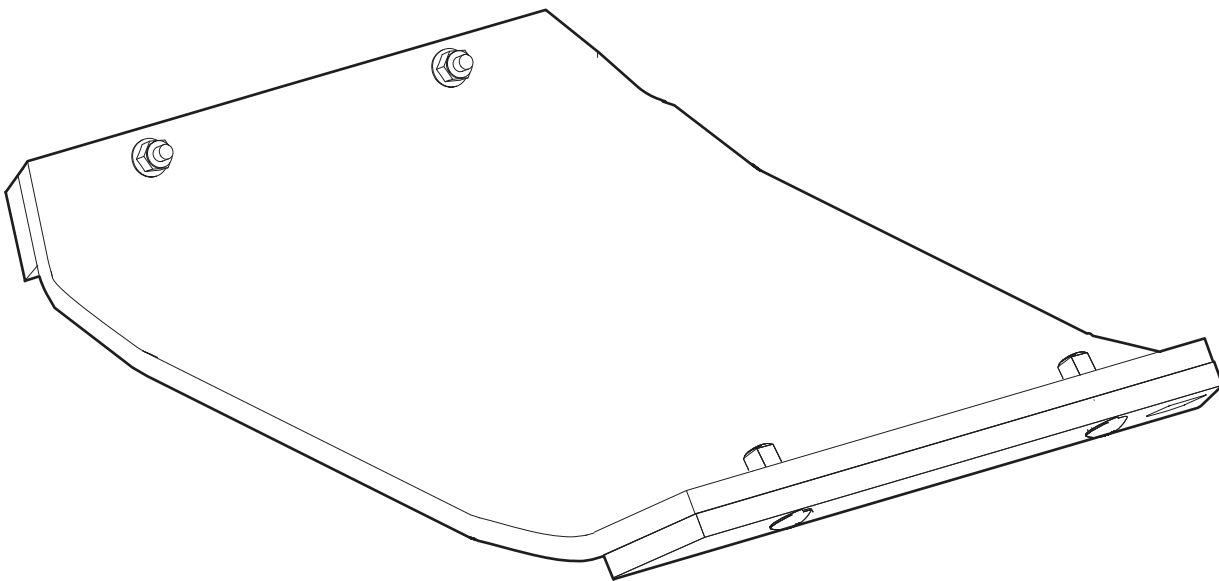

Description	Remark	Quantity	Part number
<b>Block paving plate kit</b>		1	4700 3944 65
Polyurethane plate	500 mm 19.7 in.	1	-
Bracket		2	-
Nut	M10 x 1.5 mm A3K	4	-
Screw	M10 x 45 mm 4.6 A3K	4	-



## Block paving plate kit 600 mm (23.6 in.)

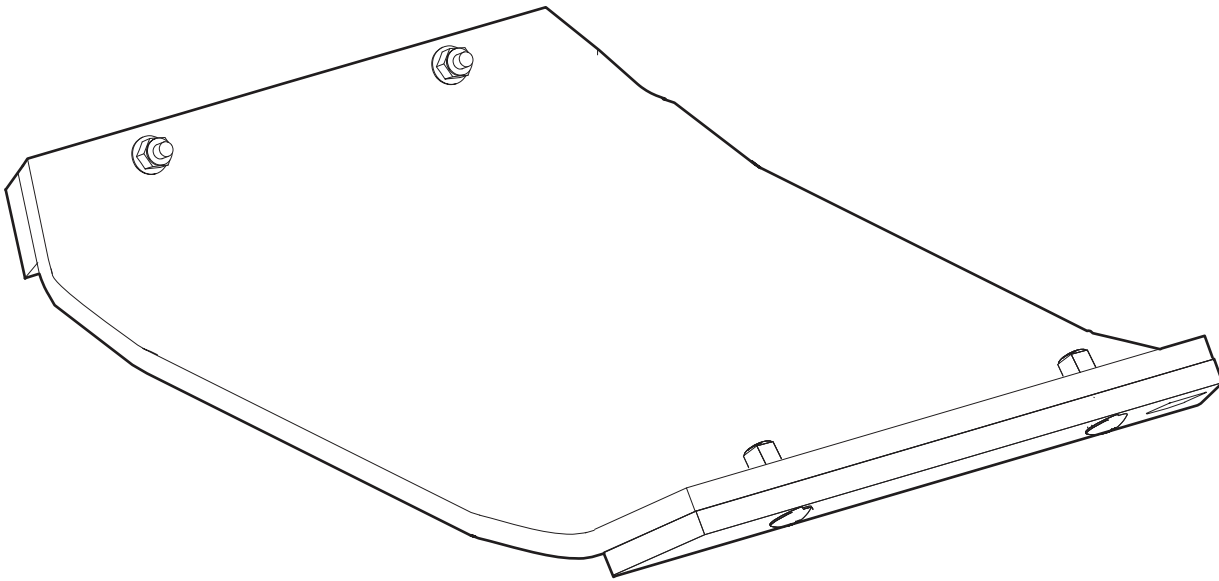

Description	Remark	Quantity	Part number
<b>Block paving plate kit</b>		1	4700 3944 67
Polyurethane plate	600 mm 23.6 in.	1	-
Bracket		2	-
Nut	M10 x 1.5 mm A3K	4	-
Screw	M10 x 45 mm 4.6 A3K	4	-

## Transport device kit

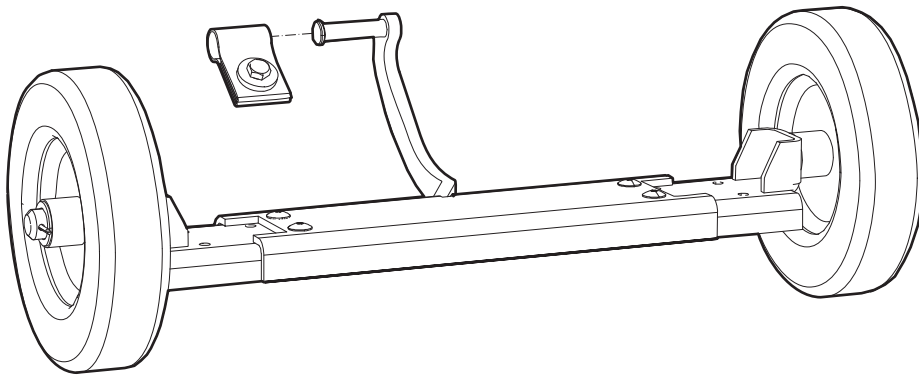

Description	Remark	Quantity	Part number
<b>Transport device kit</b>		1	4700 3949 69
Transport device		1	-
Strap		1	-
Washer	13 x 36 x 6 mm 0.51 x 1.42 x 0.24 in. 300 HV	1	-
Screw	M12 x 25 mm 8.8 A3K	1	-
Screw	M8 x 30 mm 8.8	4	-
Wheel shaft		2	-
Washer		4	-
Wheel		2	-
Split pin		2	-
Washer	8.4 x 22 x 3 mm 0.33 x 0.87 x 0.12 in. HV300	4	-
Nut	M8 A2K	4	-





Any unauthorized use or copying of the contents or any part thereof is prohibited.  
This applies in particular to trademarks, model denominations, part numbers, and drawings.

© 2011 Atlas Copco Construction Tools AB | No. 9800 1108 01 | 2011-04-01

[www.atlascopco.com](http://www.atlascopco.com)